

# NOP Coolant Unit YTH E Series EP

## Model Numbering System: TOP-YTH ① ② - ③ E VD ④ ⑤

① Motor capacity    ② Motor type    ③ Flow rate    ④ Relief pressure setting    ⑤ Filtering performance

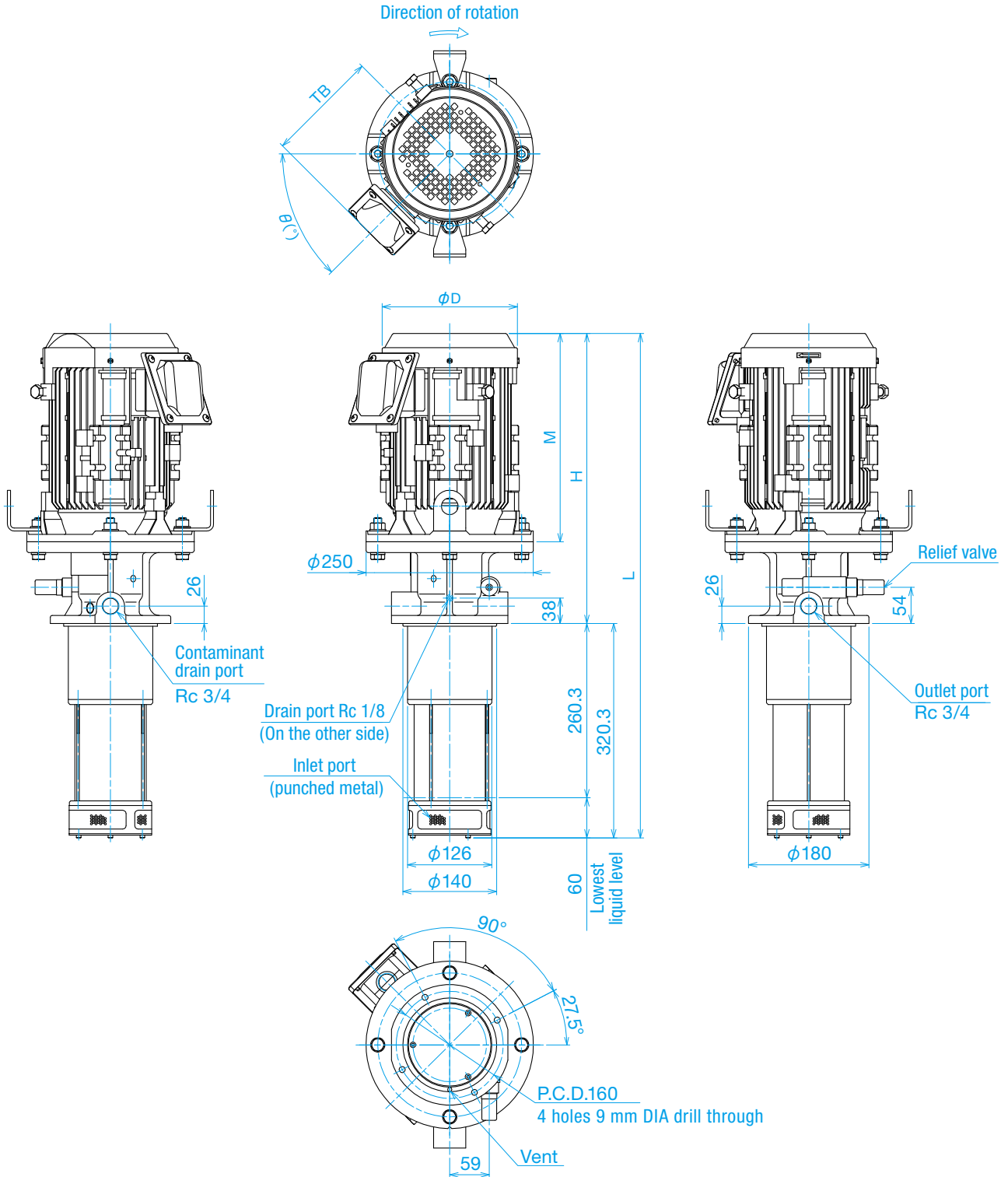

(mm)

Model	L	H	M	φD	θ(°)	TB
YTH2200A3-P008EVD*C	753.3	433	311	202	45	168
YTH2200A3-P010EVD*C	753.3	433	311	202	45	168
YTH2200A3-P016EVD*C	753.3	433	311	202	45	168
YTH3700A3-P014EVD*C	768.3	448	326	243	45	187
YTH3700A3-P016EVD*C	768.3	448	326	243	45	187